

M8x.5 ISO - H TAP ∇ 12.000
7.5 DRILL (7.500) ∇ 15.000 -(8) HOLE

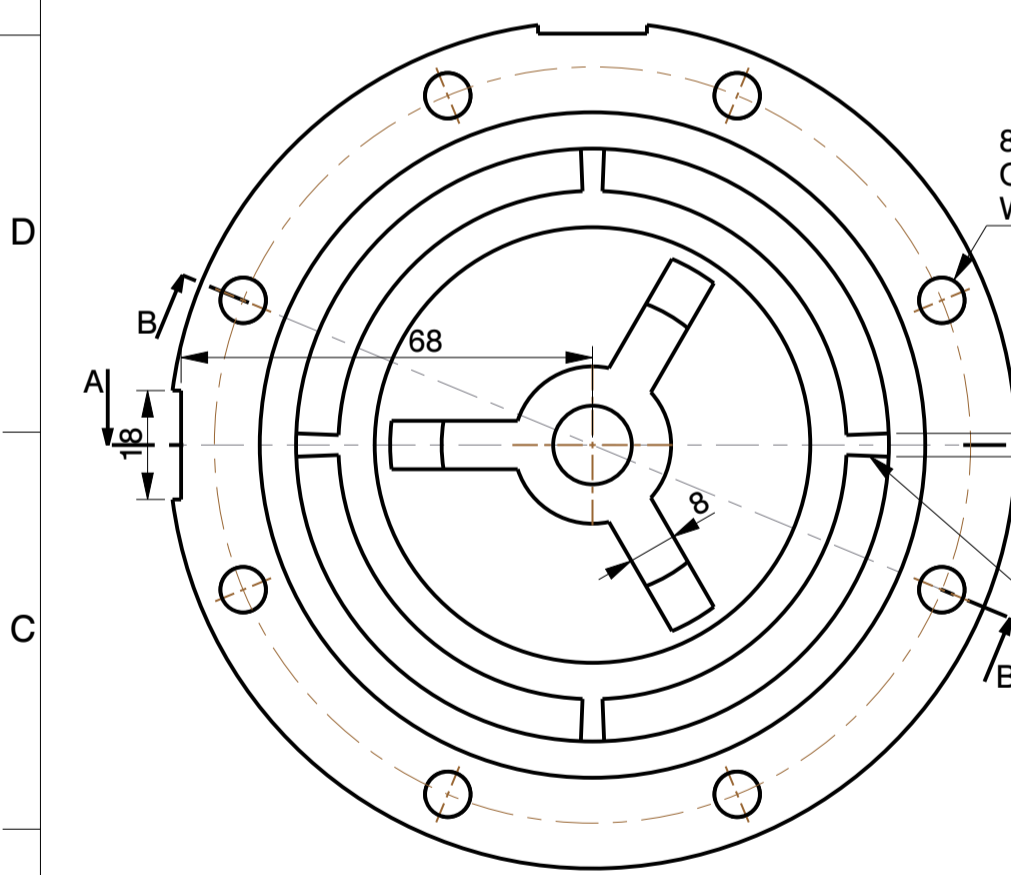

8 EQUI SPACED BLIND HOLES
OF $\phi 8.5$ * DEEP 15
WITH TAPPING OF M8 ON PCD 125

4 RIBS INSIDE
AT EQUAL DISTANCE

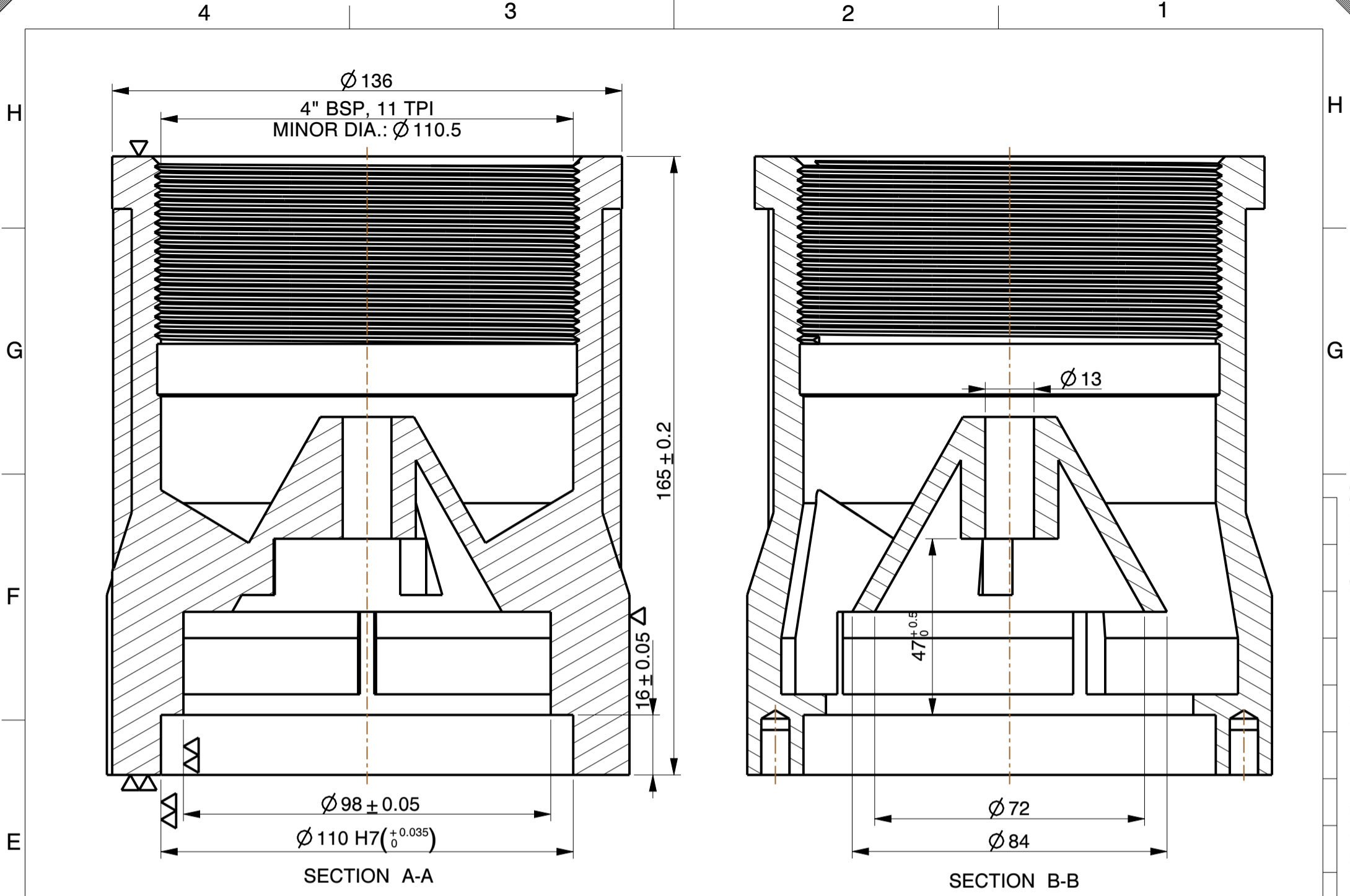
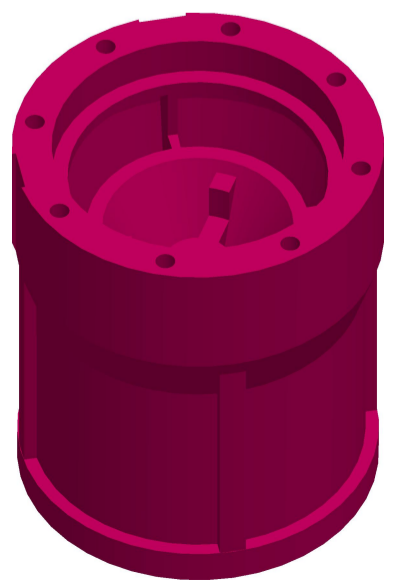
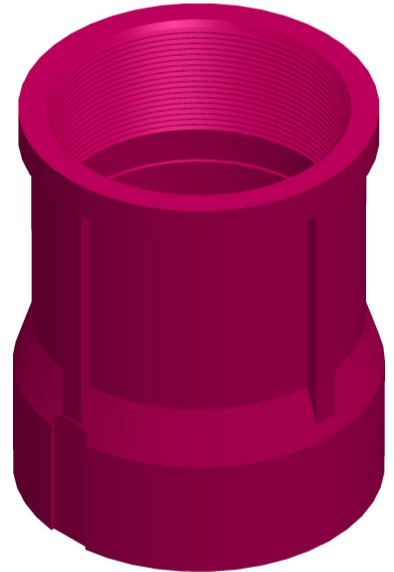

NOTE:-
1). ALL DIMENSIONS ARE IN mm.
2). DO NOT SCALE, IF ANY DOUBT PLEASE ASK.
3). ALL DIMENSIONS ARE AS CAST. (Machined in bracket)

MICROCARE TECHNIQUES P. LTD.		
Survey No.11, Nr. Kalpataru Society, Village : Zundal.		
Dist. :Gandhinagar-382421, Gujarat, INDIA. email: microcare25@microcaregroup.com		
PART NAME:	NRV 323-110 WITH CONE 4" THREAD 5 LUGS	SCALE 1:1.25
MATERIAL:	CAST IRON	DATE 5-1-2012
DESCRIPTION:	Weight:- 4.8 Kgs	