

4 3 2 1

H

G

F

E

D

C

B

A

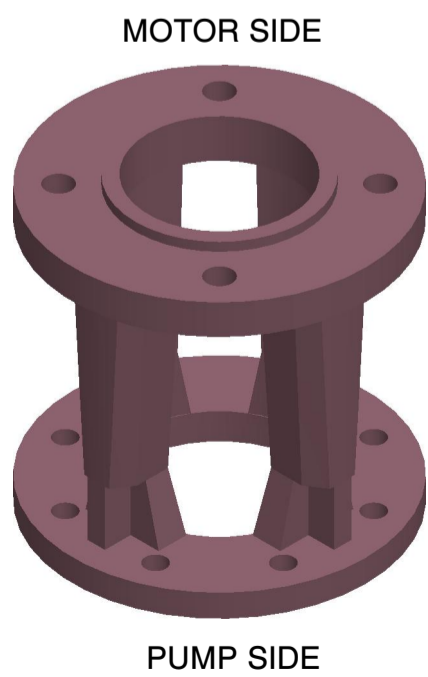
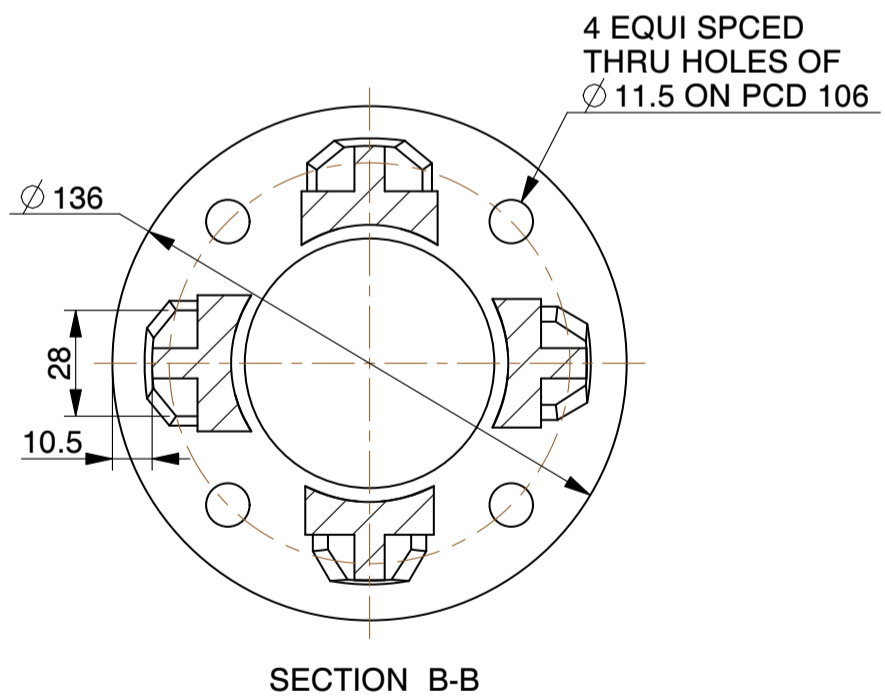
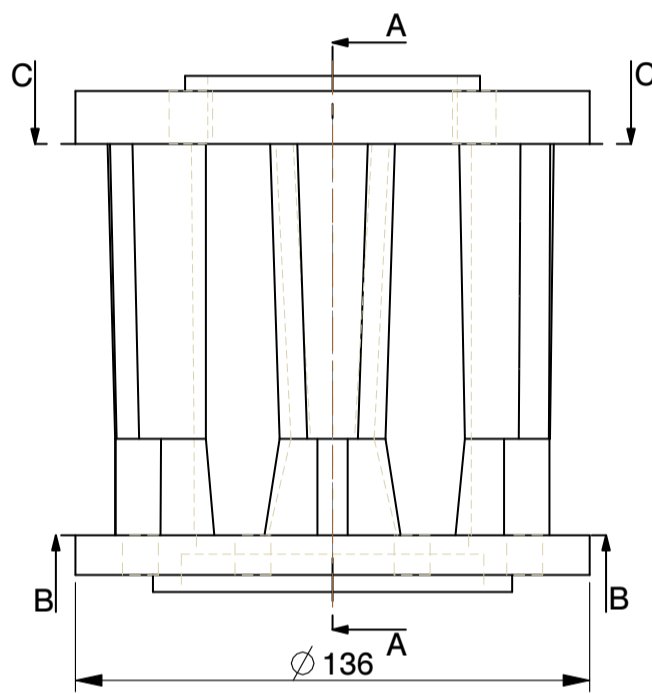
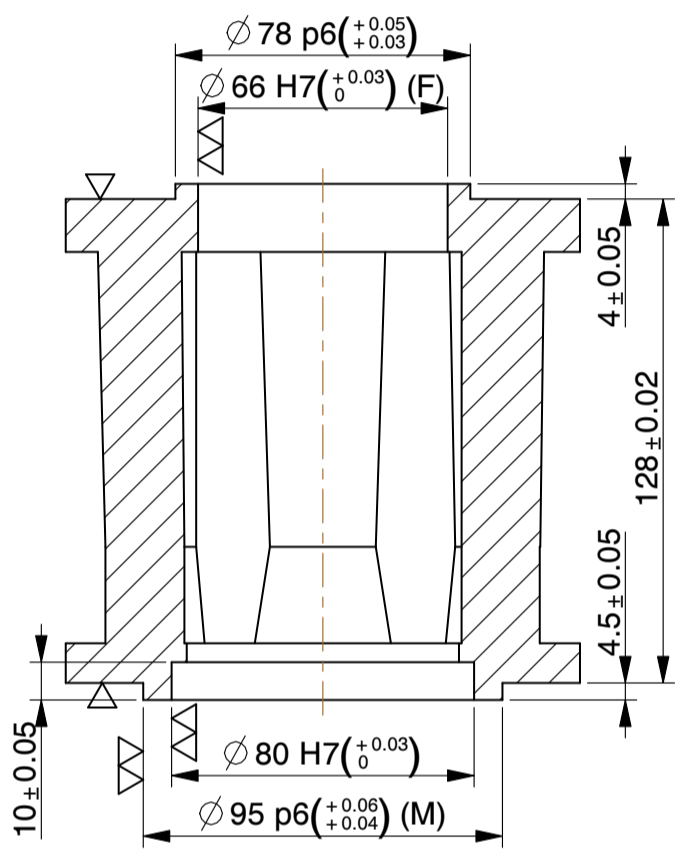
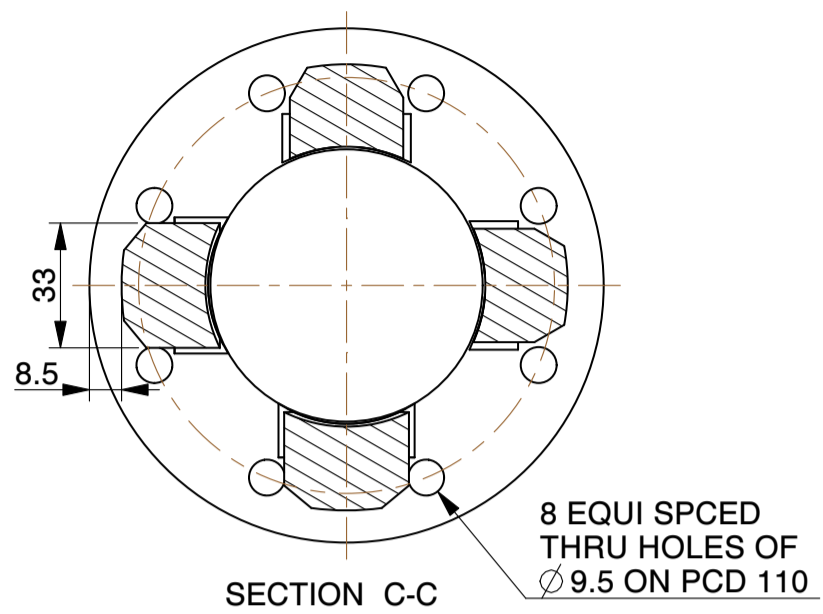

NOTE:-
 1).ALL DIMENSIONS ARE IN mm.
 2).DO NOT SCALE,IF ANY DOUBT PLEASE ASK.
 3).ALL DIMENSIONS ARE AS MACHINED.

WEIGHT (AS CAST) :- 4.6 Kg.

MICROCARE TECHNIQUES P. LTD.		
<i>Survey No.11,Nr. Kalpataru Society, Village : Zundal. Dist. :Gandhinagar-382421, Gujarat, INDIA. email: microcare25@microcaregroup.com</i>		
PART NAME:		IP 262
MATERIAL:	DESCRIPTION:	SCALE 1:2
CAST IRON	-	DATE 17-05-2011

4 3 2 1

This Document is the exclusive property of company and shall not be used, copied or communicated to third parties without their prior authorization.

Associated Model File Name : IP_262
Drawing File Name : IP_262