

4 3 2 1

H G F E D C B A

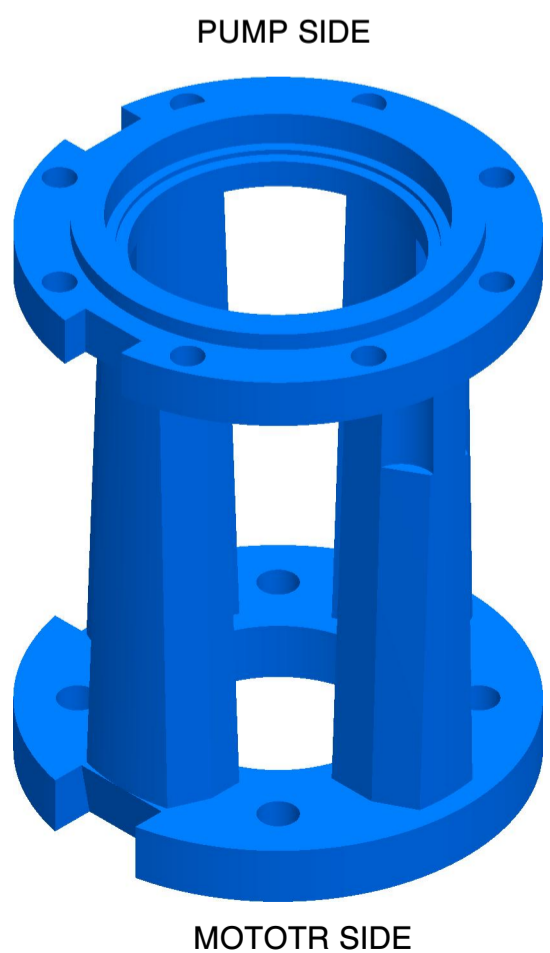
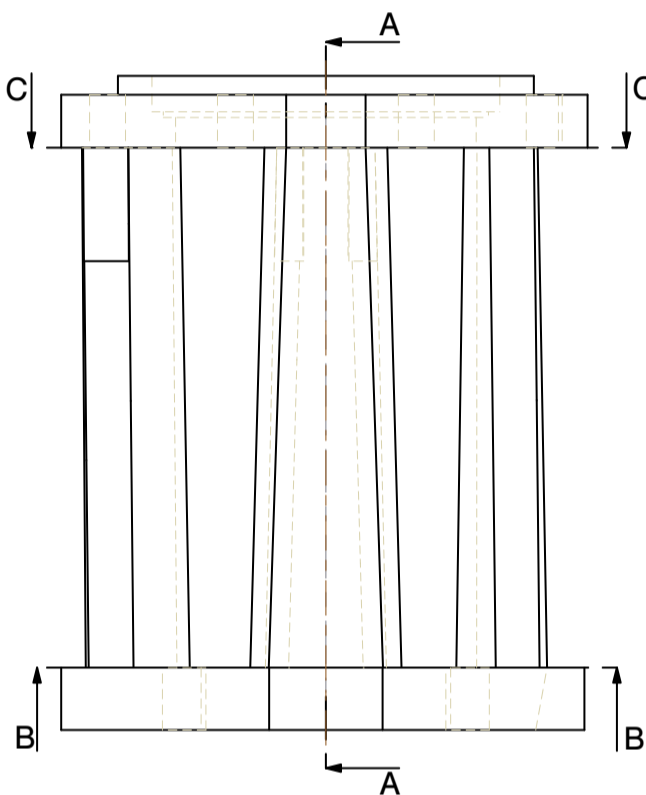
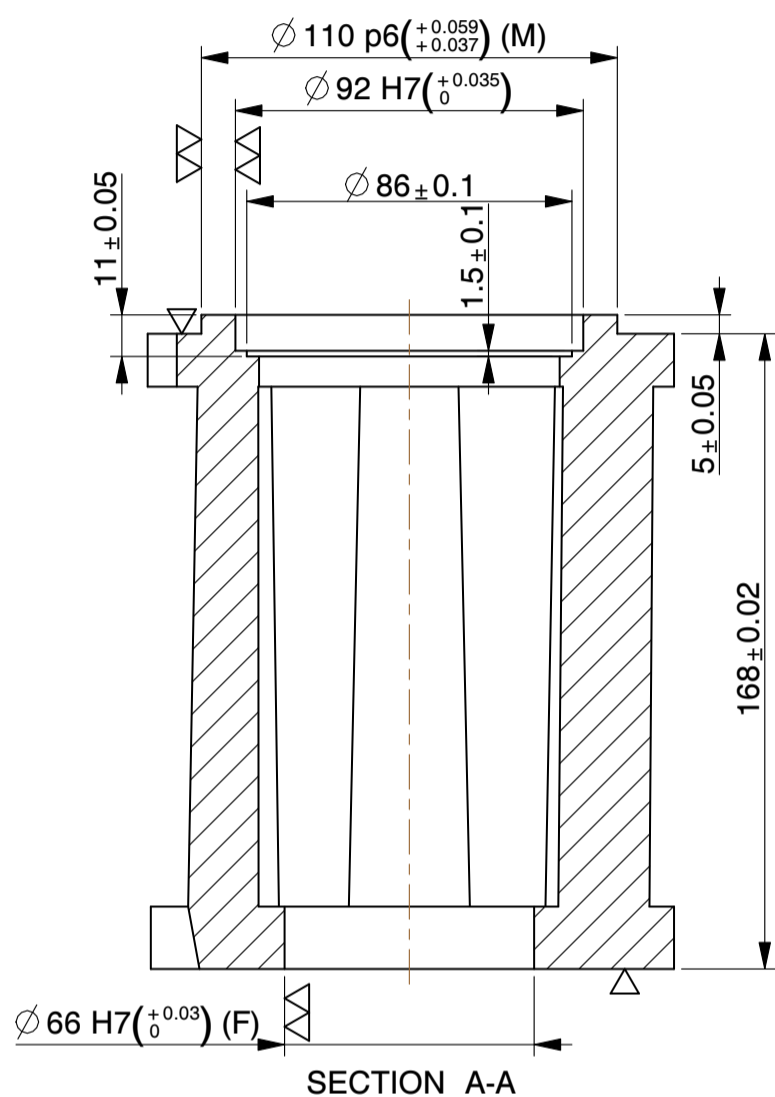
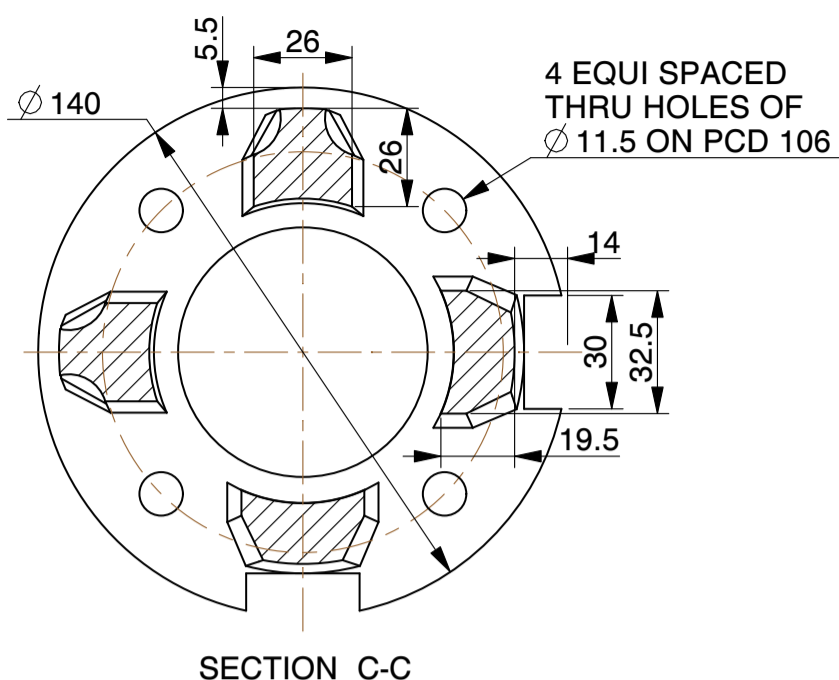

NOTE:-  
 1).ALL DIMENSIONS ARE IN mm.  
 2).DO NOT SCALE,IF ANY DOUBT PLEASE ASK.  
 3).ALL DIMENSIONS ARE AS MACHINED.

WEIGHT (AS CAST) :- 5.1 Kg.

<b>MICROCARE TECHNIQUES P. LTD.</b>		
Survey No.11,Nr. Kalpataru Society, Village : Zundal.		
Dist. :Gandhinagar-382421, Gujarat, INDIA. email: microcare25@microcaregroup.com		
PART NAME:	IP 323/110 WITHOUT MALE STEP	SCALE 1:2
MATERIAL: CAST IRON	DESCRIPTION: -	DATE 17-05-2011

4 3 2 1

This Document is the exclusive property of company and shall not be used, copied or communicated to third parties without their prior authorization.

Associated Model File Name : IP-323\_110\_WO\_MALE

Drawing File Name : IP-323\_110\_WO\_MALE

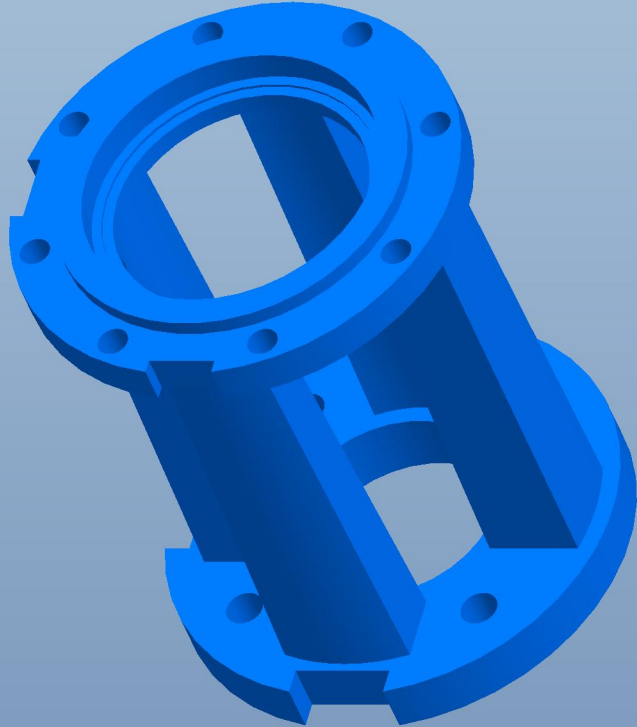

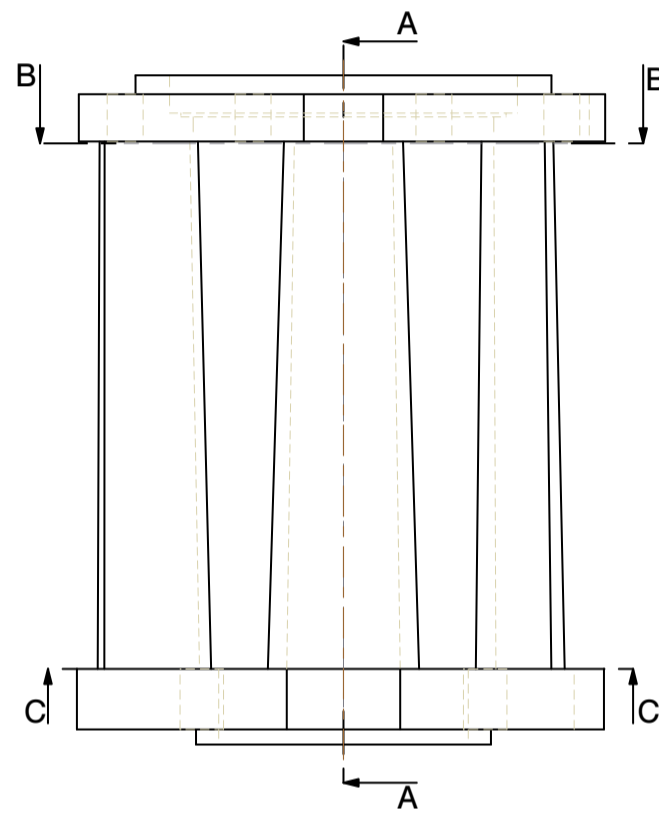
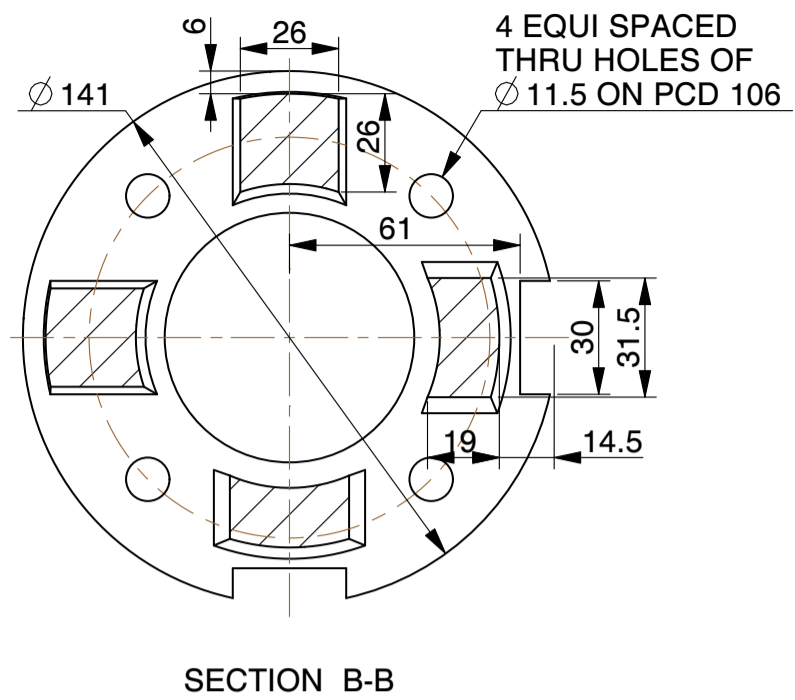
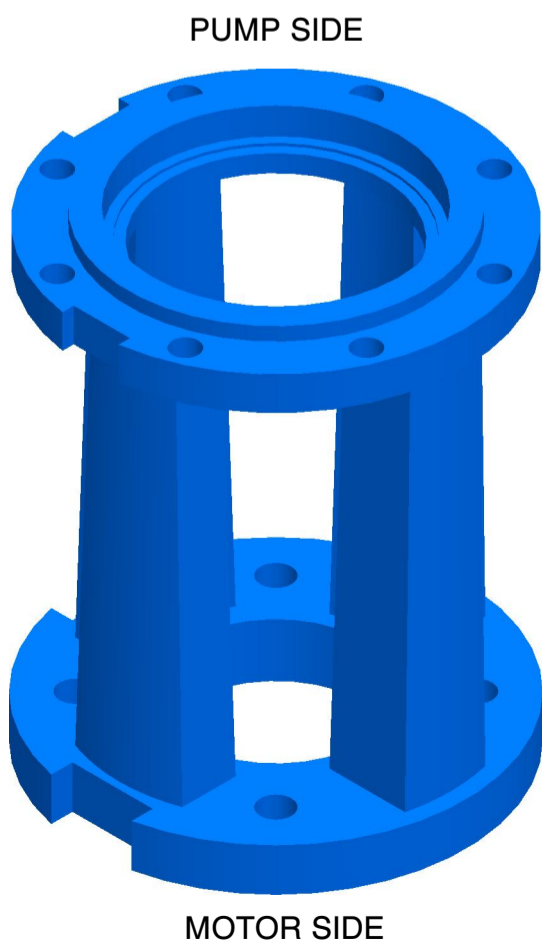
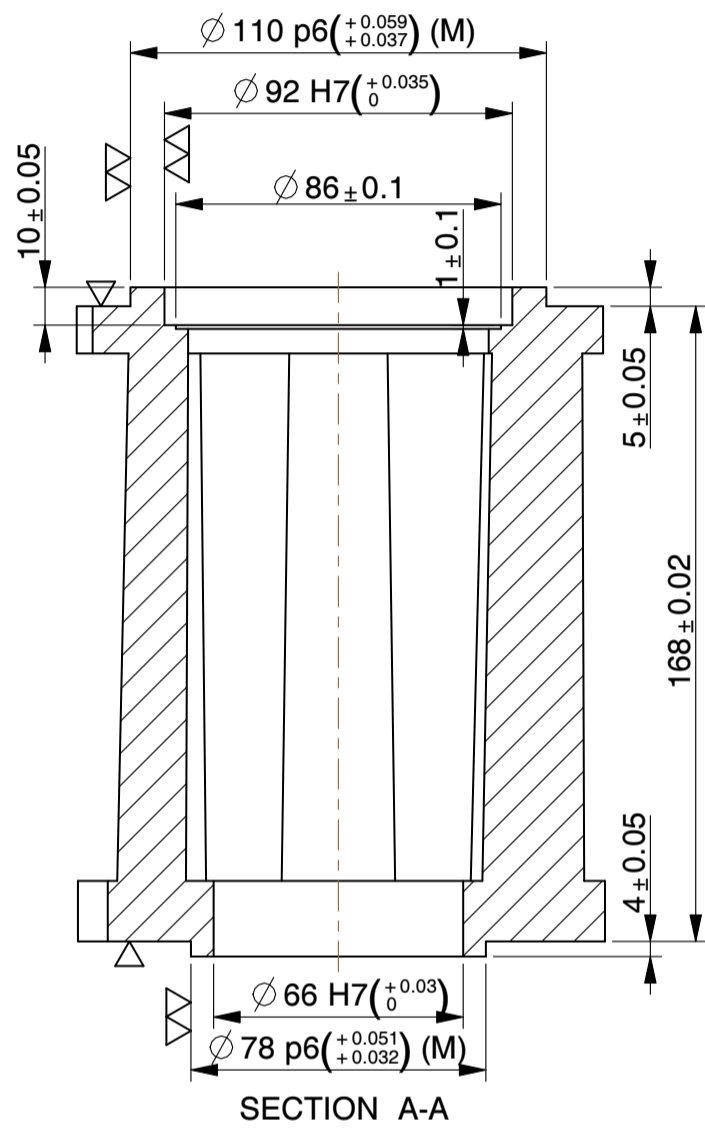

NOTE:-  
 1).ALL DIMENSIONS ARE IN mm.  
 2).DO NOT SCALE,IF ANY DOUBT PLEASE ASK.  
 3).ALL DIMENSIONS ARE AS MACHINED.

WEIGHT (AS CAST) :- 5.1 Kg.

<b>MICROCARE TECHNIQUES P. LTD.</b>		
Survey No.11,Nr. Kalpataru Society,Village : Zundal.		
Dist. :Gandhinagar-382421, Gujarat, INDIA. email: microcare25@microcaregroup.com		
PART NAME:		SCALE
IP 323/110 WITH MALE STEP		1:2
MATERIAL:	DESCRIPTION:	DATE
CAST IRON		17-05-2011