

SECTION B-B

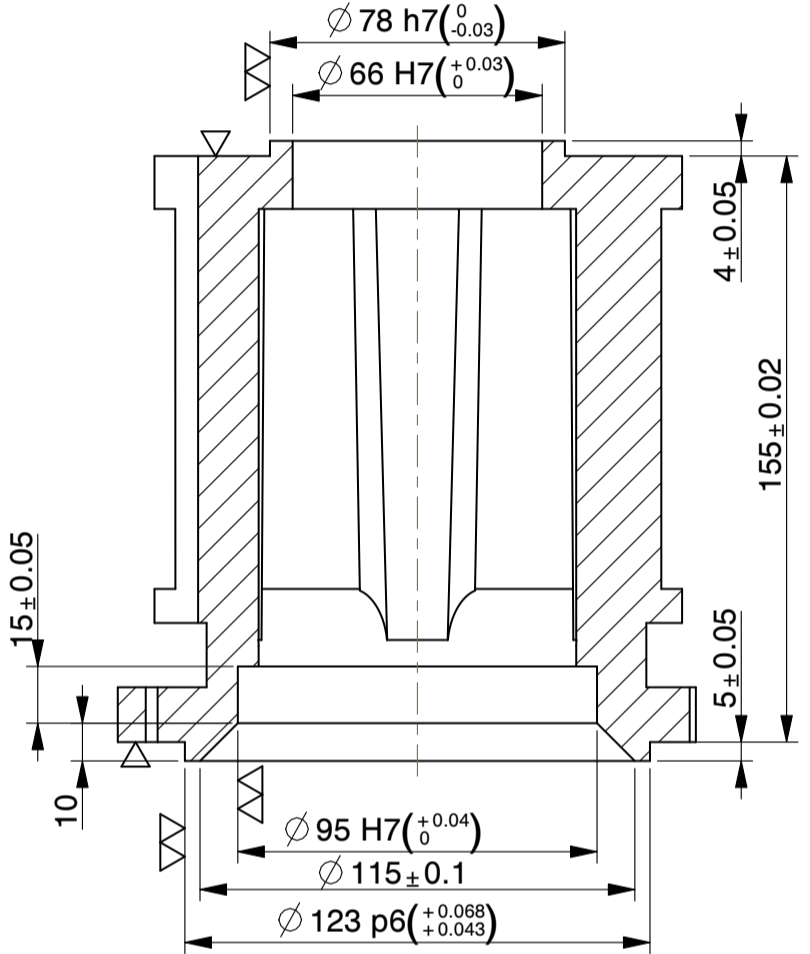

SECTION A-A

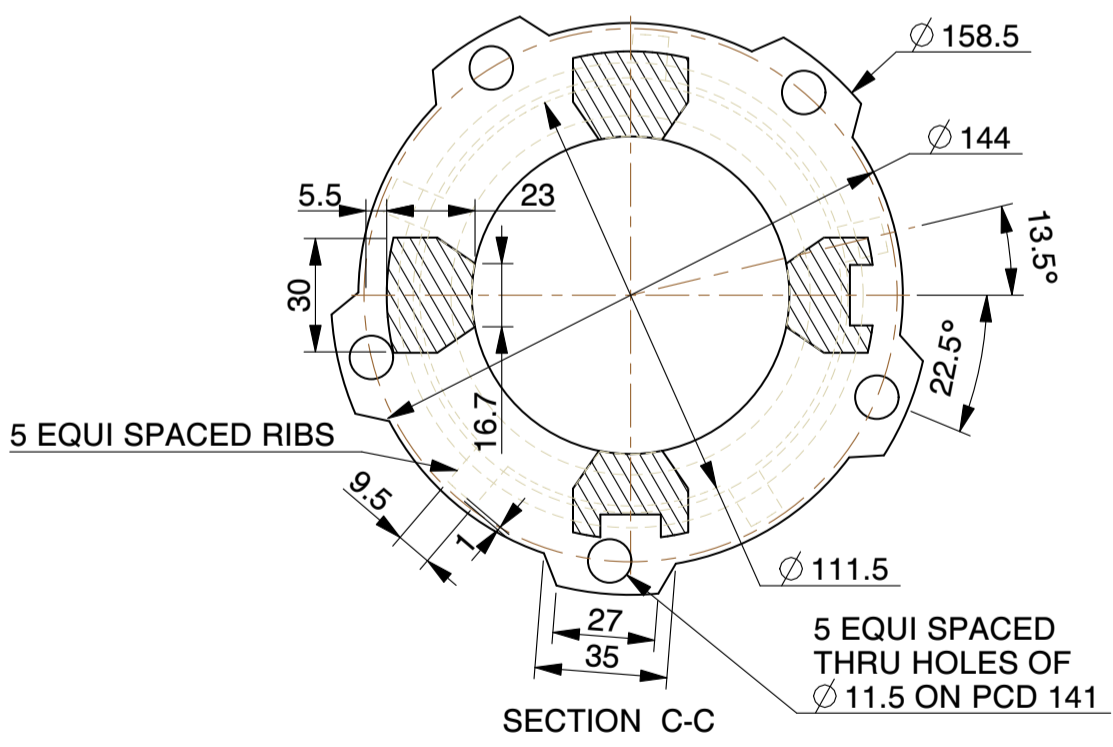
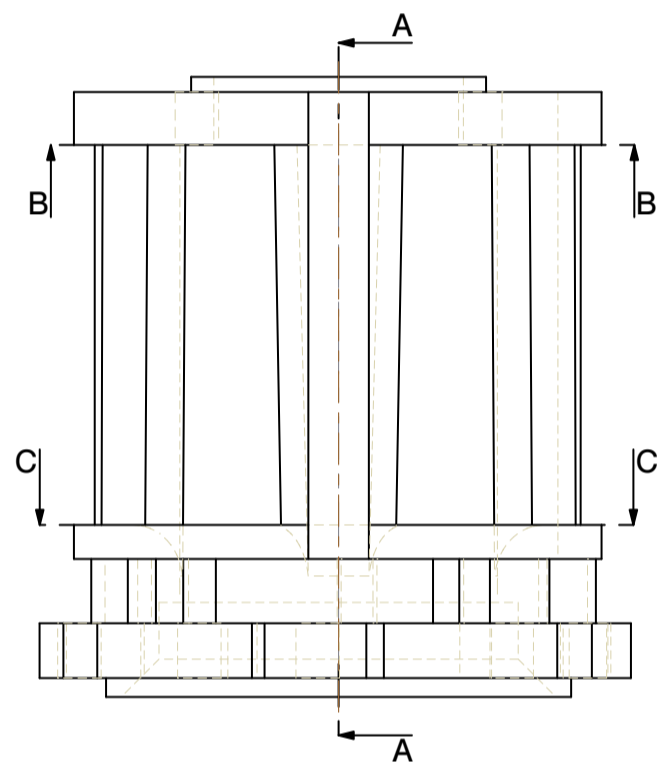

SECTION C-C

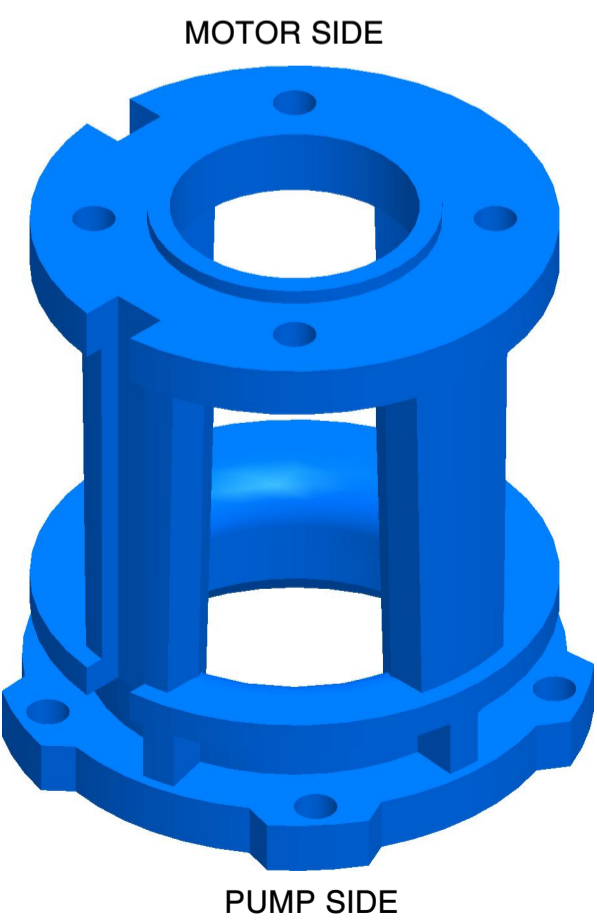

MOTOR SIDE

PUMP SIDE

NOTE:-
 1).ALL DIMENSIONS ARE IN mm.
 2).DO NOT SCALE,IF ANY DOUBT PLEASE ASK.
 3)ALL DIMENSIONS AR AS MACHINED.

WEIGHT (AS CAST) :- 5.3 Kg.

MICROCARE TECHNIQUES P. LTD.		
Survey No.11,Nr. Kalpataru Society, Village : Zundal.		
Dist. :Gandhinagar-382421, Gujarat, INDIA. email: microcare25@microcaregroup.com		
PART NAME: IP V6 TO V7 WITH 5 LUGS		SCALE 1:2
MATERIAL: CAST IRON	DESCRIPTION: -	DATE 17-05-2011