

MS - JET / MONO SHELL MOULD IMPELLER

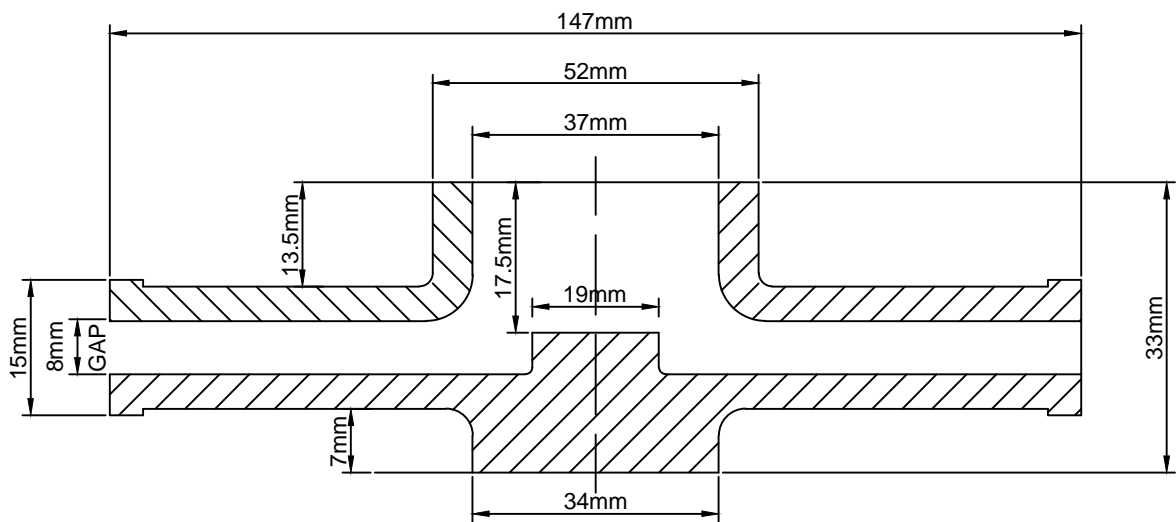

Model No	MS JET/MONO
Type of flow	-
Borewell Size	-
Flow Rate	2.50 m ³ /hr (150 LPM)
Head / Stage	18
Shut off Head	29
Power driven by pump / stage	0.75 KW (1 HP)
Rated RPM	2880 @ 50 Hz
No. of Blades	4 + 4 (Splitter) (CCW)
Production Method	Shell Moulding
Compatible Volute Model No.	-

ALL DIMENSIONS ARE - AS CAST

MICROCARE TECHNIQUES PVT. LTD.