

M 100 (INV. CAST) IMPELLER

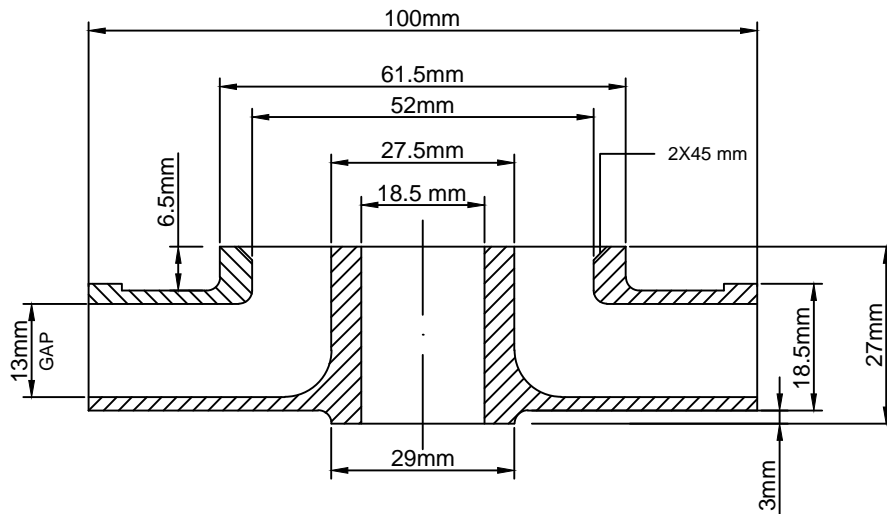

Model No	M 100
Type of flow	Radial Flow
Borewell Size	6"
Flow Rate	5.50 m ³ /hr (330 LPM)
Head / Stage	8 m
Shut off Head	12 m
Power driven by pump / stage	0.75 KW (1 HP)
Rated RPM	2880 @ 50 Hz
No. of Blades	8 (CCW)
Production Method	Investment Casting
Weight (As cast)	0.490 (kg)
Compatible Diffuser Model No.	DIFFUSER - K50

NOTE :

ALL DIMENSIONS ARE - AS CAST
 ALL DIMENSIONS ARE IN MM UNLESS OTHERWISE SPECIFIED.
 DO NOT SCALE, IF IN DOUBT ASK.