

M 242 / 1 IMPELLER

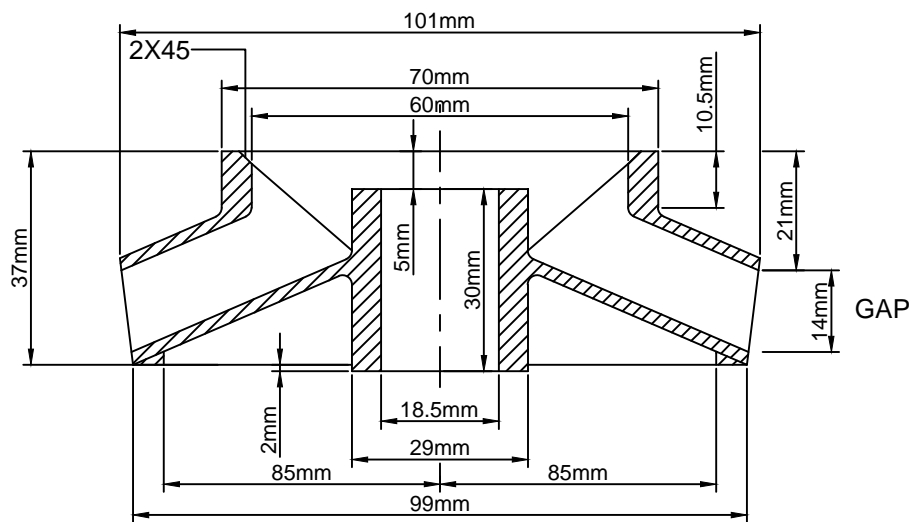

Model No	M 242/1
Type of flow	Mixed flow
Borewell Size	6"
Flow Rate	8.33 m ³ /hr (500 LPM)
Head / Stage	7 m
Shut off Head	11 m
Power driven by pump / stage	1.12 KW (1.5 HP)
Rated RPM	2880 @ 50 Hz
No. of Blades	6 (CCW)
Production Method	Investment Casting
Weight (As cast)	0.500 (kg)
Compatible Bowl Model No.	BOWL- 242

NOTE :

ALL DIMENSIONS ARE - AS CAST

ALL DIMENSIONS ARE IN MM UNLESS OTHERWISE SPECIFIED.

DO NOT SCALE, IF IN DOUBT ASK.

MICROCARE TECHNIQUES PVT. LTD.