

# M - 1.25 - HIGH HEAD (50 FT) IMPELLER

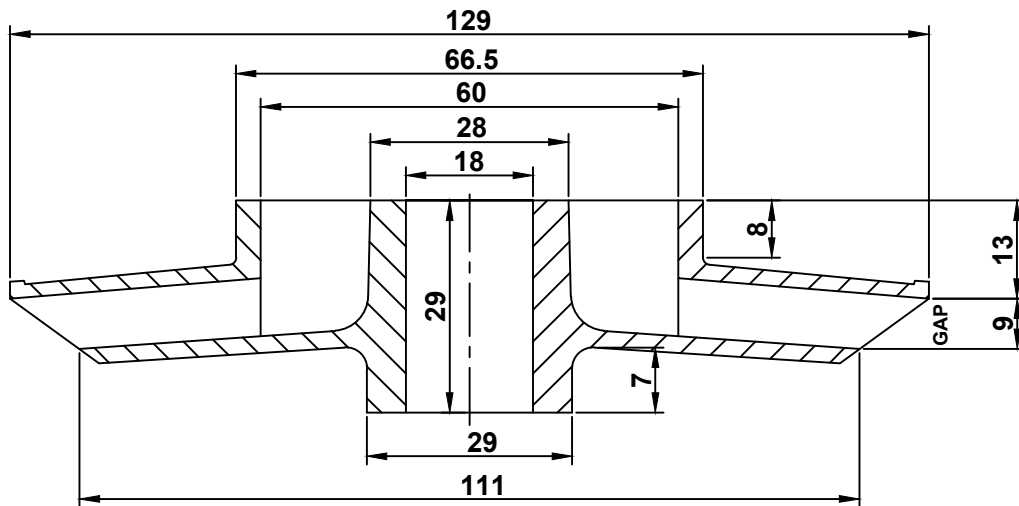

Model No	M 1.25 HH
Type of flow	Radial Flow - High Head
Borewell Size	6"
Flow Rate	4.58 m <sup>3</sup> /hr (275 LPM)
Head / Stage	12 m
Shut off Head	15.5 m
Power driven by pump / stage	0.93 KW (1.25 HP)
Rated RPM	2880 @ 50 Hz
No. of Blades	5 (CCW)
Production Method	Investment Casting
Weight (As cast)	0.575 (kg)
Compatible Diffuser Model No.	DIFFUSER - SS 125

**NOTE :**

ALL DIMENSIONS ARE - AS CAST

ALL DIMENSIONS ARE IN MM UNLESS OTHERWISE SPECIFIED.

DO NOT SCALE, IF IN DOUBT ASK.